



*Current or voltage operated units for annunciation and target applications.*

### Features and Benefits

- Current operated units available
- High speed DC voltage operated units available
- Drawout case available
- Molded case with 3 mounting options available

### Applications

- When a target is required
- When alarm or similar functions required
- Interposing relay in conjunction with transformer SP relay

### Protection and Control

- Auxiliary contacts and targeting



## Description

Generally two specific forms of the HAA are available, a current operated unit and a voltage operated unit. Example: HAA15A4 is 0.2/2 A DC and the HAA15B5 is a 125 VDC unit. Also, two general case designs are available. The single units such as HAA 15 use a molded plastic case with glass window and all others the standard drawout case.

The HAA relays contain a standard target unit which is a small hinged armature type relay with a "U" shaped magnet frame, a fixed pole piece, an armature which operates the normally open contacts and the target, and an operating coil.

## Applications

The HAA auxiliary relay may be used whenever a target is required. Also, each unit has at least one set of contacts available for alarm or other similar use. See Selection Guide and Fig. 1 on next page for contact arrangements.

A typical application would be to obtain a local annunciation of an abnormal condition and to relay the alarm to a central annunciator. With this arrangement the abnormal condition would operate one of the HAA coil circuits dropping the target and causing the associated unit contacts to relay the alarm to the remote annunciator.

The HAA16B, HAA16C, and HAA19A relays are special high-speed DC voltage relays with a pickup of 1 cycle or less at rated voltage for use with transformer pressure relays for increased security. The connections of the HAA16B and HAA16C are shown in Fig. 2. Its coil is shorted by a normally closed contact of the transformer pressure relay to prevent the HAA relay from operating in case a voltage surge

should flash over the normally closed contacts of the pressure relay.

## Contact Ratings

The contacts will make and carry 30 A momentarily and will carry 6 A continuously.

For resistance values, pickup values and the current carrying ability of all the current operated HAA relays, refer to the GE Power Management CD or home page. The appropriate data for the voltage-operated HAA relays may be found in the tables below.

## Burdens

Since these are DC relays the burdens may be easily calculated. In the case of voltage operated relays the burden in W may be found by using the following expression:

$$PDC = \frac{V^2}{Rt} = \text{Burden (W)}$$

V = voltage rating of relay  
Rt = total resistance (coil plus external resistance)

For current operated relays use the following expression:

$$PDC = I^2Rt = \text{Burden (W)}$$

I = Applied Current

## Application

Fig. 2. Schematic for application of HAA16B or HAA16C relay with transformer fault pressure relay

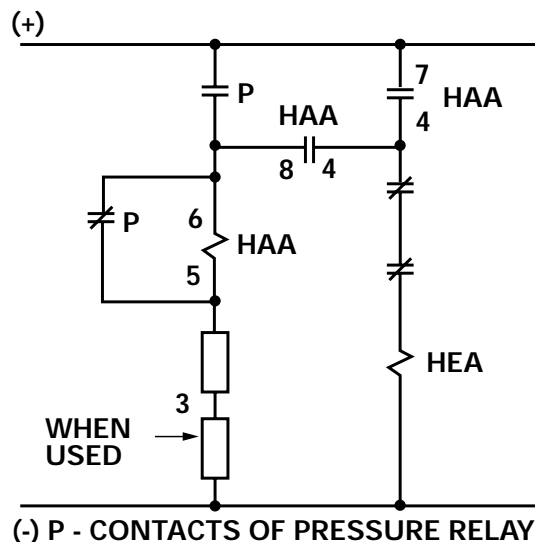

## Voltage Units Resistances

Model Number	Contin. DC Rating (V)	Maximum Pickup (VDC)	Dropout (VDC)	Coil Resistance (Ohms)	Internal Resistance (Ohms)	External Resistance (Ohms) <sup>②</sup>
---- <sup>①</sup>	48	41	4.8	840	—	—
---- <sup>①</sup>	125	106	12.5	5600	—	—
---- <sup>①</sup>	250	212	25.0	5600	5600	—
HAA16B5 & C5	24	13	2.4	14	75	—
B4 & C4	32	15	3.2	14	100	—
B1 & C1	48	22	4.8	95	350	—
B2 & C2 <sup>②</sup>	125	60	12.5	95	350	650 <sup>②</sup>
B3 & C3 <sup>②</sup>	250	120	25.0	95	350	1650 <sup>②</sup>
HAA19A2A	48	22	4.8	95	350	—
A1A	125	60	12.5	95	1000	—

<sup>①</sup> Available on all HAA models except models HAA16 and HAA19

<sup>②</sup> These resistors are supplied automatically with the relay and should not be ordered separately

Fig. 1. Contact configurations

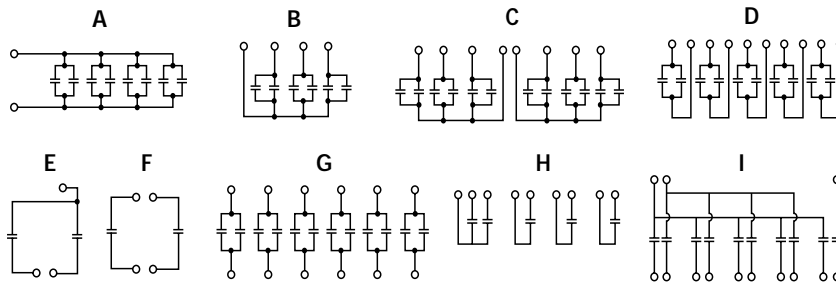

Selection Guide

# Units Per Case	Case	Group	VDC	Current DC (A)	Contact Configuration	Approx. Wt. in lbs (kg)	
						Net	Ship
1	15A	4	—	0.2/2.0	Figure 1E	2 (1)	3 (1.4)
	15A	5	—	0.6/2.0			
	15B	6	48	—			
	15B	5	125	—			
	15B	4	250	—			
	15E	1	—	0.2/2.0			
	15F	1	125	—			
	15H	1	48	—	Figure 1F		
	15H	2	125	—			
	15H	3	250	—			
	16B	5*	24	—	Figure 1E	3 (1.4)	4 (1.8)
	16B	4*	32	—			
	16B	1*	48	—			
	16B	2*	125 <sup>Ⓞ</sup>	—			
	16B	3*	250 <sup>Ⓞ</sup>	—			
	16C	5*	24	—			
	16C	4*	32	—			
	16C	1*	48	—			
16C	2*	125 <sup>Ⓞ</sup>	—				
16C	3*	250 <sup>Ⓞ</sup>	—				
19A	2A	48	—	Figure 1H	8 (3.6)	12 (5.4)	
19A	1A	125	—				
3	14B	3A	48	—	Figure 1B	6 (2.7)	10 (4.5)
	14B	2A	125	—			
	14B	1A	250	—			
	14C	1A	—	0.2/2.0			
4	12A	4A	—	0.2/2.0	Figure 1A	7 (3.2)	10 (4.5)
	12B	2A	48	—			
	12B	1A	125	—			
5	11A	1A	—	0.2/2.0	Figure 1D	8 (3.6)	12 (5.4)
	11A	2A	—	0.6/2.0			
	11B	3A	48	—			
	11B	2A	125	—			
	11B	1A	250	—			
18A	1A	125	—	Fig. 1I	8 (3.6)	12 (5.4)	
6	13A	1A	—	0.2/2.0	Figure 1C	8 (3.6)	12 (5.4)
	13B	3A	48	—			
	13B	1A	125	—			
	13B	2A	250	—			
	13D	1A	—	1.0			
	13E	1A	250	—	Fig. 1G		

Order Code Breakdown

HAA	***	**	*	Contact Option
	11A			S2 Case
	11B			S2 Case
	12A			S1 Case
	12B			S1 Case
	13A			S2 Case
	13B			S2 Case
	13D			S2 Case
	13E			S2 Case
	14B			S1 Case
	14C			S1 Case
	15A			Back connected and cover with glass window
	15B			Back connected and cover with glass window
	15E			Front connected and cover with glass window
	15F			Front connected and cover with glass window
	15H			Back connected and cover with glass window
	16B			Back connected and cover with glass window
	16C			Front connected and cover with glass window
	18A			S2 Case
	19A			S2 Case
	XX			See Group column under Selection Guide
	F			Semi-flush (not for models that use S1/S2 cases)
	*			regular mounting

Ⓞ Includes external resistor.

\* Used as an interposing relay after the transformer sudden pressure relay.

