

DS Agile C264

Dual-bay Modular Substation Controller

The DS Agile C264 substation controller is a sophisticated solution supporting multiple applications and functions for substation control, communication, monitoring, protection, and automation. Flexibility, reliability and ease of use are among the top features required in a substation computer; the latest release of DS Agile C264 has these features and is equipped with a new generation CPU (CPU4v2) compatible with 64 Bits technology.

A combination of dual redundant fiber optic Ethernet, modular I/O, expandable design, and an extensive library of functions make the C264 the ideal solution for a wide array of applications in substation digital control systems.

Key Benefits

- Flexible, modular and expandable design to support many applications
- Dual-bay management with two embedded CT/VT acquisition boards including measurements and sampled values streams to reduce the number of controllers
- New 64 Bits processor that allows virtual address ranges greater than 4GB in size
- HSR/PRP RedBox capability to connect PRP/HSR non-compliant devices to the redundant network, reducing the number of RedBoxes
- Reduce engineering costs and amount of devices, wiring, cabling and training required by using the multi-functional capabilities
- IEC 61850-8-1 and IEC 61850-9-2 standard compliance for interoperability
- LCD graphical display for user-friendly local control, monitoring and maintenance
- Seamless integration with existing substation assets with flexible interfaces, expandability and support of legacy and cutting-edge communication protocols
- Proven solution with more than 50,000 units installed worldwide

Applications

- Full digital substation and conventional substation
- Transmission, distribution, utilities and industrial
- Green field and brown field substation



Multi-function Controller

- Bay Computer (BCU)
- Bay Computer + Protection Functions (BCPU)
- Remote Terminal Unit (RTU)
- Switchgear Control Unit (SCU)
- Protocol converter
- Substation gateway

Automation and Control

- Traditional data management function (inputs and outputs)
- Feeder manager (protection and control)
- Substation automation processor
- Sequence-of-Events Recorder (SER)
- Automatic Voltage Regulation (AVR)
- Multi-bay management
- Measurement center
- Load shedding control
- IEC 61131-3 soft logic
- Control and protection scheme optimization

Advanced Communication

- Up to 6 physical ports
- 0 ms network redundancy
- IEC 62439-3 PRP and HSR



Features

Bay/Substation Interlocking

The DS Agile C264 BCU provides two methods of interlocking:

- A logical equation-based method
- A topology-based method, using pre-defined rules and substation topology

Interlocks are managed as close to the process as possible in order to provide the best security of operation. Interlocking conditions are graphically displayed in order to immediately identify any possible constraints and make the appropriate changes before issuing the command.

Trip Circuit Supervision

The purpose of this function is to supervise the continuity of the trip circuit of a circuit breaker. Two options are available to supervise the circuit breaker's trip circuit continuity: two wires and four wires to monitor continuity either when the circuit breaker is closed or when it is opened or closed.

The four-wire option permits verification of the continuity whether the CB is open or closed. For single pole operated circuit breaker, the C264 can supervise the continuity of the trip circuit independently for each phase.

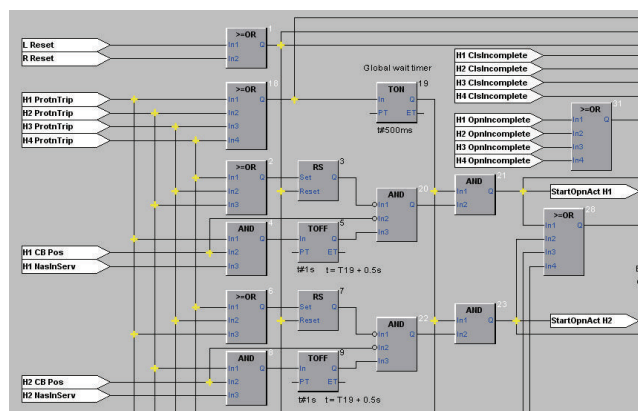

Figure 1 Sample of logical equations

Automatic Voltage Regulation

The Automatic Voltage Regulation (AVR) function is used to maintain automatically the correct secondary-side voltage of a tap-changer (OLTC) equipped transformer.

DS Agile C264's AVR is a compact voltage regulation solution for IEC 61850 systems in electrical substations. It is able to manage one single transformer or up to four transformers in parallel.

C264 AVR provides:

- Active and reactive compounding in order to maintain the voltage at a remote location
- Homing in order to adjust a transformer to the voltage of the busbar to which it will be connected
- For transformers in parallel: minimizing circulating current method, master/follower mode
- Optimized transformer ratio

Auto-Recloser

The DS Agile C264 can manage one auto-recloser per bay. The integrated auto-reclosers can operate in 1 phase and/or 3 phase mode. Up to four auto-reclosing cycles are available and the time delay for each is independently configurable. Auto reclosers can be initiated either internally in the bay unit or via external protection devices using digital inputs.

Synchro-Check

The synchro-check function can be used in conjunction with automatic or manual reclosure. The function (limited to one bay) determines the difference between the amplitude, phase angles and frequencies of two voltage vectors and uses this information to determine whether or not to close the breaker. Locking and coupling modes are available and a deadline and dead bus logic are also included.

IED Gateway and Data Concentrator

One of the main features of the C264 is to concentrate and process data. This information can come from a variety of sources, both analog and digital. For example, when re-using existing equipment, analog data can be acquired directly from current and voltage transformers and digital data can be acquired over serial communication links or via hardwired links.

The DS Agile C264 manages many types of data: OLTC position, control signals, measurements, disturbance records, settings, etc. Each item of qualified data is uniquely referenced in order to ensure full consistency of the information, as well as allowing it to be re-used in other parts of the system.



Figure 2 DS Agile C264 front view (40TE case)

Remote Terminal Unit

The DS Agile C264 can be used as a Remote Terminal Unit (RTU), offering a powerful solution for SCADA communication, Sequence-of-Event Recording (SER), and can be integrated into a substation Digital Control Systems (DCS).

- Up to 10 000 digital inputs
- Up to 1 200 digital outputs
- Up to 15 independent acquisition racks, communicating over Ethernet
- Up to 2 serial links on a rack (RS232/RS485)
- Up to 4 simultaneous SCADA connections
- Up to 16 IEDs connected via each RS485 serial interface

Sequence-of-Event Recorder

A reliable event recorder is integrated in DS Agile C264 for accurate event monitoring in electrical substations. Benefiting from accurate time synchronization, maintenance over Ethernet and an expandable architecture, the SOE function is able to locally store and print up to 2048 time-stamped events with a 1 ms resolution. The 200 most recent events can be viewed on the local LCD screen. It also offers printer status monitoring.

Switchgear Control Unit

The DS Agile C264 can be used as a Switchgear Control Unit (SCU). The SCU acquires binary values from primary devices and forwards them to protection and control IEDs over the Ethernet process bus. It conversely receives binary control commands that are dispatched to the relevant substation's items through rugged binary output boards. This allows reducing the amount of copper wiring used in the substation, thus minimizing failure risks and optimizing operation costs.

In addition, when used as SCU, DS Agile C264 is also able to perform logic equations through Programmable Scheme Logic (PSL) to improve substation interlocks which can now only rely on field data and equipment.

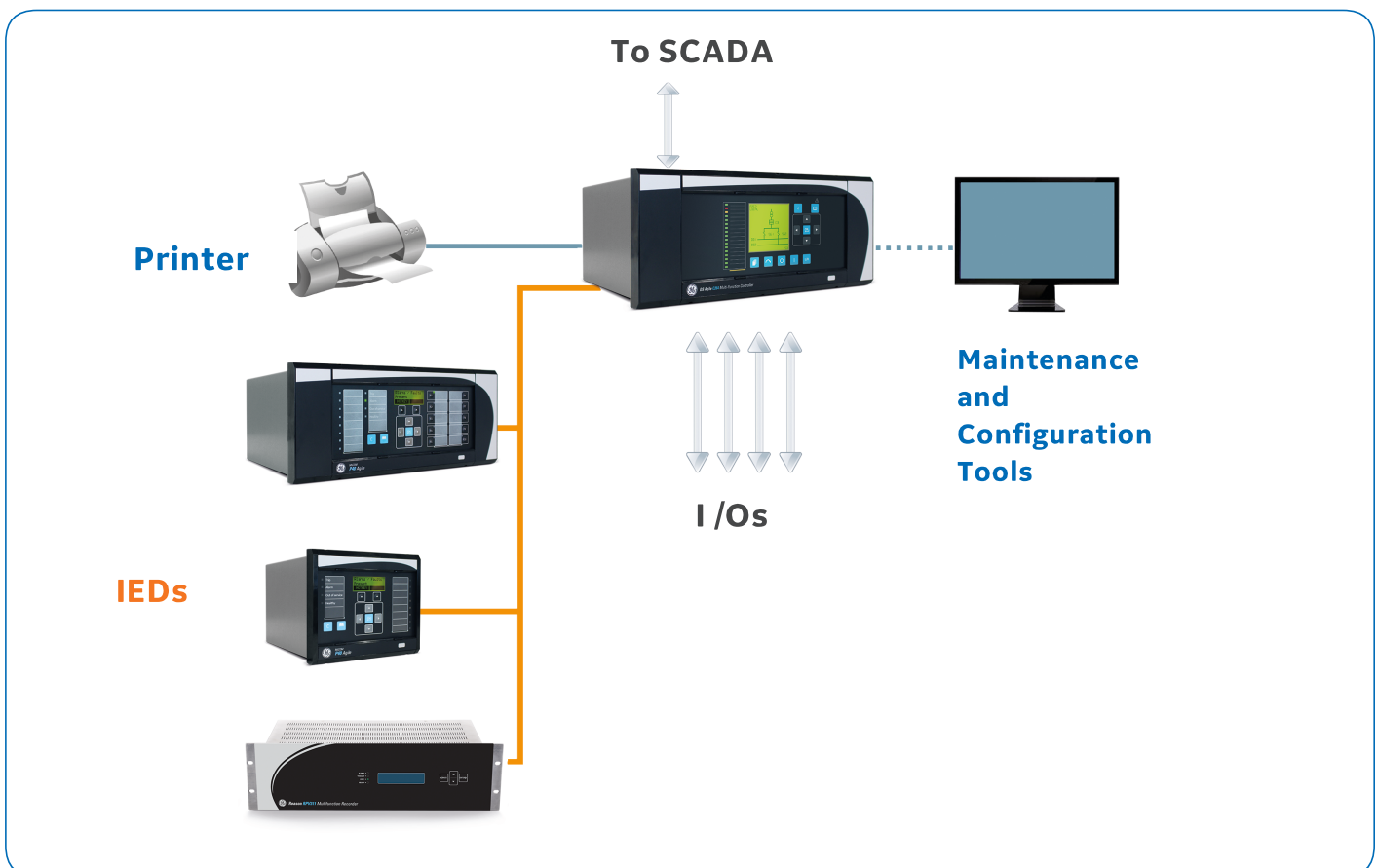

Figure 3 Simple control system architecture using a single C264 substation controller

Technical Data

Communication Protocols

The DS Agile C264 is fully compatible with many communication standards such as IEC 61850 (UCA2), IEC 60870-5-104, DNP3, IEC60870-5-101/103 and MODBUS.

Redundancy

At substation level and/or bay level, an optional redundant C264 can be used to avoid the loss of critical functions.

Digital Inputs

The DS Agile C264 offers five types of digital inputs:

- Single point
- Double point
- Multiple point
- System input for internal C264 information
- Logical combination of digital inputs

All inputs are acquired and time-stamped with an accuracy of 1 ms.

Digital Input Processing

In addition to de-bouncing, many customizable filtering functions can be used to process digital inputs, including:

- Toggle filtering
- Persistence filtering
- Motion filtering
- Undefined state filtering

Additionally, a digital input can be manually suppressed, substituted, forced invalid and detected as faulty. Digital inputs can then be transmitted on the substation LAN using the desired protocol.

Binary Counters

Two types of binary counters are available; single counters for single data points and double counters for double data points.

Counters can be transmitted periodically or on request. In the event of a supply interruption the counters can resume from their previously stored values.

Digital Outputs

Digital outputs can be used to apply a switching voltage to an external device. These outputs can be controlled in one of three ways:

- Select Before Operate once (SBO once)
- Select Before Operate many (SBO many)
- Direct execution

The SBO once mode is used for controls via set points or ancillary devices, as well as synchronized or non-synchronized circuit breakers, transformers, disconnectors and earthing switches. The SBO many (selection, execution, and de-selection) control sequence is used for the control of transformers.

Encoded Digital Data

The DS Agile C264 can interpret a group of digital inputs as an encoded digital value. Binary, Binary Coded Decimal (BCD), gray code, decimal and 1 among N types of encoding can all be processed. These values can represent data such as process measurements and tap changer (OLTC) positions.

Analog Inputs

Analog outputs can be used to interface with auxiliary devices (measurement viewers, generators, motors, etc). The analogue outputs are powered from an external supply (48 Vdc) and can maintain their value even if the C264 is powered down.

Measured and Derived Values

Directly measured values of voltage and current can be measured using the transducerless measurement board. Many different values can be calculated from the measured values including:

- RMS currents and voltages
- Network frequency and phase angle
- Active, reactive and apparent power – total and per phase
- Power factor
- Sequence components
- Derivatives: df/dt , dV/dt , etc

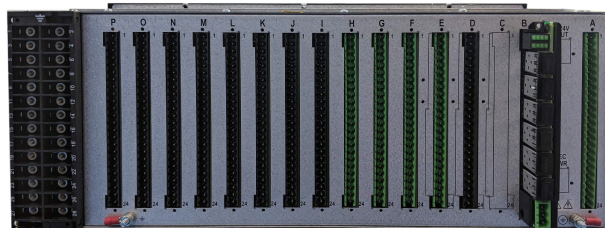

Figure 4 DS Agile C264 rear view (80TE case)

Waveform Recording

The DS Agile C264 BCU provides two types of waveform recording: Fast Waveform Record (FWR), which stores samples at the maximum sampling frequency and Slow Waveform Record (SWR), which stores RMS measurements over a longer period. Both modes can run simultaneously. Recording can be triggered by the change of state of binary digital inputs/outputs, measurement threshold violations or a request from an operator. Waveform records are stored using COMTRADE 2001 binary format.

Power Quality

The DS Agile C264 can measure the percentage Total Harmonic Distortion (THD) (up to and including 15th harmonic) and the Total Demand Distortion (TDD) on voltage and currents.

Self-Monitoring

Comprehensive self-monitoring procedures, including power-on and continuous testing, ensure that internal hardware or software errors are detected and do not cause malfunctions. If a fault is detected an alarm will be issued and/or the watchdog contacts will change state depending on the fault severity.

Maintenance Web Server

The maintenance web server can be used to visualize maintenance data (Hardware/Software, Communication, I/O values) and to download the up-to-date event log. It is directly accessible with a standard Internet browser.

Programmable Logic

An operator can configure specific control sequences or automation schemes (e.g. automatic switching, System Integrity Protection Schemes (SIPS), load shedding). Such applications can be based on local or remote data. Similarly, the outputs can perform local or remote actions. Programmable logic can be implemented in the C264 using either Programmable Scheme Logic (PSL) or the Programmable Logic Controller (PLC). PSL is for fast automation applications (<5ms). It is event-driven, thus there is no cycle time. The optional PLC tool is fully compliant with IEC 61131-3. It can be used for complex or sequential automation applications.

Local Interface for Control Operation and Display

The control of switching devices is possible using a keypad and a graphical backlit LCD. Operations can be performed in a simple and intuitive way via up to 12 switchable displays for bay control. Additionally, there are dedicated panels for monitoring (measurements, event lists, alarms, etc.), display and maintenance. If required, the operator panel can be mounted separately from the DS Agile C264 (up to five meters away). Access barriers can be used to prevent inadvertent or unauthorized operations.

Event Logging

Up to 2048 events can be stored in non-volatile memory. The events are time-stamped and stored in chronological order.

Cyber Security

DS Agile C264 embeds various must have features in term of Cyber security:

- Role Based Access Control
- Local Authentication
- Security Event Logs
- Password Policy
- Conforms to BDEW Whitepaper
- Designed with an IEC62443-4-1:2018 certified Secure Development Lifecycle Process
- Provide the necessary capabilities to build an IEC62443-3-3:2013 compliant solution



Time Synchronization

The DS Agile C264 internal clock can be synchronized via:

- An operator
- IRIG-B GPS clock (via the IRIG-B input)
- Ethernet SNTP server, IEEE 1588 PTPv2
- Remote SCADA (DNP3.0, IEC 60870-5-101 or IEC 60870-5-104)

In addition, the DS Agile C264 can be configured as an SNTP server on an Ethernet network.

Configuration and Settings

Based on pre-defined libraries, individual configurations can be created rapidly. It is possible to modify the C264's settings on line, with the DS Agile S1 setting tool (over Ethernet). The DS Agile C264 provides two configuration databases: one active and one inactive for fast and secure switching in case of system configuration changes.

Managed Network

The DS Agile C264 is natively equipped with 6 independent Ethernet ports to connect to two separate LANs such as the local station bus and a remote SCADA.

The native switch application allows to manage Virtual LANs, to use SAN ports as Redbox to connect non-IEC 62439-3 IEDs, and reduce the number of extra switches to achieve an optimized network architecture.

Additional integrated redundant fiber optic Ethernet switches are optionally available, utilizing either IEC 62439-3 Parallel Redundancy Protocol (PRP) and High-availability Seamless Redundancy (HSR) ring protocol.

Process Bus

The DS Agile C264 is delivered with state-of-the-art digital substation applications, such as:

- Double access point for logical station and process bus segregation
- IEC 61850-9-2 sampled values management
- Fast (1 ms) acquisition and transmission of binary signals and commands through standard IEC 61850-8-1 GOOSE messages
- Dynamic voltage reference selection



Performance and Capabilities

I/O Processing Capabilities

Including direct and IED points, the DS Agile C264 can process up to:

- 10000 Digital inputs
- 1200 Digital outputs
- 1024 Analog inputs
- 128 Digital counters
- 128 Digital setpoints
- 8 Current Transformers (CTs)
- 10 Voltage Transformers (VTs)
- 128 Tap position indications

Local HMI

Detachable up to 5 or 15 meters (optional)

Storage Capacities

The following records are stored in non-volatile memory:

- 2048 events, 1 ms time stamped, in the sequence of event log (circular buffer)
- Up to 8 Slow or Fast Waveform Records (SLW or FWR)
- FWR records store up to 8 analog measurements (32 samples per cycle) and up to 128 digital inputs/outputs. The total recording time is equal to 9.6s
- SWR records store up to 8 RMS measurements (time calculation settable from 1 cycle to 1 hour) and up to 128 digital inputs/outputs. The total recording size is equal to 5000 values

Five waveform and disturbance files from IED devices connected to the C264.

Communication Capabilities

Ethernet communication:

- 10/100/1000 Base-TX, 100 Base-FX, 1000 Base-SX/LX
- Protocols include UCA2 or IEC 61850, IEC 60870-5-104 (multi-client) or DNP3.0 IP
- Embedded Ethernet switch module with up to six ports (permitting a compact connection of various devices or input/output extensions)

Serial communication:

- Up to two SCADA or four IED links per device
- SCADA protocol can be switched between DNP3.0, IEC 60870-5-101 and MODBUS
- IED protocol can be switched between DNP3.0, IEC 60870-5-103, MODBUS and IEC 60870-5-101
- Transmission rate is configurable up to 115.2 kbps

Multi-Bay Management

Management of various bays in a single unit is possible within following limits:

- 2 bays with CT/VT acquisition or Sampled values acquisition
- 128 without AC analog acquisition
- Mixed configuration is possible within the 128 bays limit

General Accuracy

- 1 ms clock accuracy when synchronizing via SNTP or IRIG-B input
- 1 ms time tagging of digital inputs
- Digital outputs operating time, typically <7 ms
- Analog inputs are accurate to 0.1% of the full scale on the transducer
- Programmable scheme logic execution time is <5 ms
- The configurable automation functions on the Programmable Logic Controller (PLC) can be scheduled from 10 ms up to several seconds

Direct CT/VT Accuracy

- 80 sampled values per period
- 0.2% accuracy for AI and RMS values full scale
- 0.5% accuracy for P, Q, S calculations
- 0.5% accuracy for sequence components (Id, Ii, Io, Vd, Vi, Vo) and power factor
- 0.01 Hz accuracy for frequency
- 1° accuracy for phase angles
- Calculation up to 15th harmonic

For more information please contact
GE
Grid Solutions

Worldwide Contact Center

Web: www.GEGridSolutions.com/contact
Phone: +44 (0) 1785 250 070

GEGridSolutions.com

IEC is a registered trademark of Commission Electrotechnique Internationale. IEEE is a registered trademark of the Institute of Electrical Electronics Engineers, Inc.

GE, the GE monogram are trademarks of General Electric Company.

GE reserves the right to make changes to specifications of products described at any time without notice and without obligation to notify any person of such changes.

C264BCU-Brochure-EN-2022-03-Grid-GA-0828. © Copyright 2022, General Electric Company.
All Rights Reserved.

